

A Study on Turbine Blade Fatigue Protection

Prabakaran S

Power Technologies, Substation Automation
ABB India Development Centre
Bangalore, India
prabakaran.s@in.abb.com

Pradeep G

Power Technologies, Substation Automation
ABB India Development Centre
Bangalore, India
g.pradeep@in.abb.com

Abstract — The generator's prime mover is susceptible to abnormal frequency operation, and turbine blade fatigue is the main concern. As blade fatigue is cumulative and non-reversible, the turbine abnormal frequency protection should govern the duration of abnormal frequency operation and thus limiting the possibility of turbine damage. This turbine protection is acting as backup protection for the generator. In this paper, the need of turbine blade protection, the method of protection according to IEC standard 60034-1 and IEEE Standard C37.106 are discussed.

Keywords—Resonant Frequency, Accumulation of time, Frequency band, Voltage band.

I. INTRODUCTION

In power system, generator is the main equipment to have uninterrupted power supply. During major system disturbance the generator and the prime mover suffer severe problems due to operation of turbine-generator running in abnormal frequency. This situation leads the power system engineers to concentrate more on turbine-generator control to bring back to usual frequency. Specifically, the turbine protection is considered with respect to the possible damages due to load shedding and overload conditions which are main cause of frequency deviation.

There are a lot of protection principles have been used in the power system to prevent the system shutdown to minimize the equipment maintenance and damage costs by proper monitoring of turbine-generator. Practically it is impossible to design a turbine blade to withstand all mechanical stresses due to resonances during every steam flow stimuli. Hence operations, at frequencies other than the rated or near-rated frequencies without any time tolerance are not acceptable. The abnormal frequencies in the system can lead the turbine blades additional loss of life during their operation. The load shedding algorithm in the utility is made to adjust the load based on the capability of turbine. Due to some disturbances in the power system may take the turbine-generator overloaded for certain periods and it leads under frequency and sometimes the turbine-generator experiences under loaded resulting over frequency problems. This oscillatory nature of frequency is mostly unpredictable and this makes complexity for the design of turbine blade [1].

In general, the over frequency due to sudden rejection of loads can be restored to normal frequency by doing some

control action without tripping the units. In another case, the under frequency due to extra load on turbine-generator do have severe problems and it could lead to system collapse. Knowing the above mentioned issues the turbine blade is designed to withstand the frequency variation to certain level. Manufacturer of turbine should have specified the frequency range that should be sustained by turbine blade. This condition should be studied to avoid the serious problems in the power system like system shutdown. Recognizing this limitations many utilities are using the under frequency relays with timers to protect the turbine from damages. The purpose of this paper is to provide reliable protection for the turbine from abnormal frequency operations. The paper reviews the IEC and IEEE standards and provides outlines about the procedures for achieving security and reliability.

II. TURBINE CAPABILITY

A. Turbine abnormal Frequency Capability

Relatively prime movers are more restrictive than generators, as the short time mechanical resonance can cause severe damage to turbine for minor disturbances in frequency. Generally the steam turbines are designed for various steam pressures with multiple stages. The turbine blades are placed in multiple rows with different lengths and the steam is introduced into the turbine through nozzles to influence on the blades for the rotation. This continuous flow of steam with different pressure result into deformation of the blade beyond their designed value. The stress on the blade is depend on the speed of rotation of the turbine and the length of the blade and its design dictates resonant frequency. Hence the turbine blade is designed in such a way that the natural frequencies remains far away from the rated fundamental frequency and its harmonics to avoid the substantial mechanical stress on the blade during the normal frequency operations [3]. The mechanical stress on the blade during resonant frequency conditions could be heavily damaging and cause the reduced turbine life time.

During the resonant conditions the vibrating stress on the turbine blade can be as much as 300 times greater than the stress during non-resonant condition. The mechanical stress for a typical resonance curve is given in Fig 1. In this case the stress level between 48 Hz and 52 Hz is acceptable with respect to turbine blade design, hence the operation between these frequency limits is allowed for certain time duration as mentioned by the manufacturer. Out of this frequency limit the

operation is prohibited. Also the stress amplitude is nonlinear with respect frequency change. Out of the limited frequency range the stress on the blade is increasing exponentially. This would weaken the turbine blade and eventually required more maintenance work.

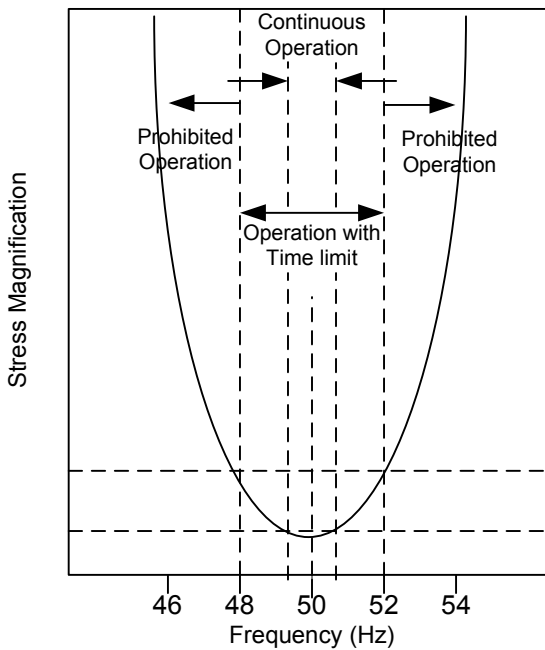

Fig. 1. Stress magnification with respect to frequency operation

For a particular blade design the change in turbine speed can produce excitation frequencies that may coincide with the natural frequency of that blade and that is illustrated using Campbell diagram in Fig 2.

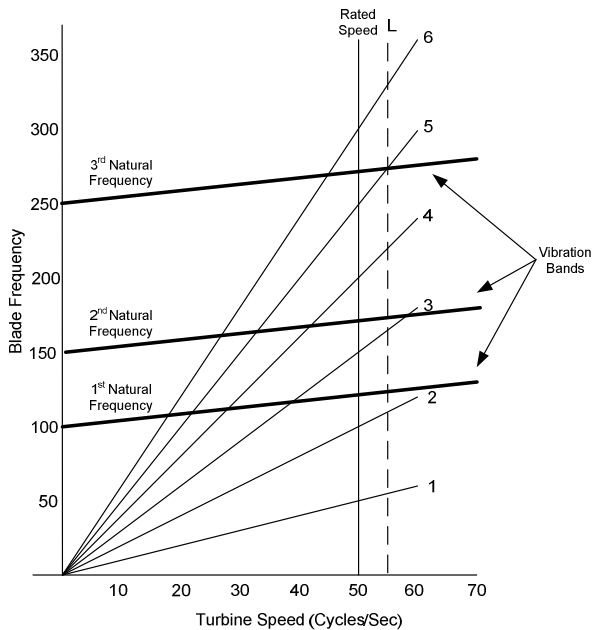

Fig. 2. Typical turbine blade Campbell diagram

The diagonal lines from 1 to 6 indicates the rated frequency and its integer multiple frequencies of the turbine speed. The vertical line at 50 Hz shows the rated speed of the turbine. The horizontal lines represents the blade natural frequencies. From the figure, it can be visualized that the given blade design does not have natural frequencies that coincide with 50 Hz or any harmonics up through the sixth. The blade design is made in such a way that the small changes in turbine speed from rated speed would not intersect the natural frequencies of the blade. However large variations on the turbine speed would cause an intersection with one or more of the natural frequency bands at some multiple of the new operating speed and such a situation is illustrated with vertical line L.

B. Turbine Limitations

The turbine blades at multiple stages is designed to withstand for various pressure conditions. The extreme stress at resonant frequency operations is controlled by system damping and it is not enough to achieve fully. Moreover the designing of blade by the manufacturer to handle the stress for long time due to mechanical resonance for all steam flow stimuli to withstand strength is not possible economically. Hence the operation of the turbine apart from the rated and near rated speed is time-restricted in the frequency band limits specified by the each turbine manufacturer for various blade designs [3]. Manufactures decides the frequency band limits considering the following conditions.

- a) The natural frequencies of blades;
- b) The withstand strength during normal operation under pitting corrosion and erosion of the blade edges;
- c) The change in natural frequency of the blades due to erosion and corrosion;
- d) The change in resonant frequencies with respect to the effect of additional loss of blade life incurred during abnormal operating conditions.

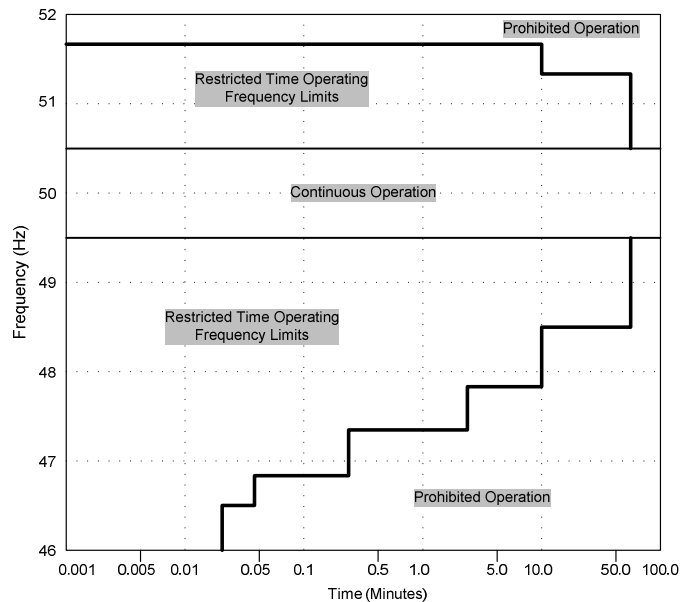

Fig. 3. Time restricted turbine operations for different frequency band limits

Practically the turbine frequency do not settle at one frequency band limit in their operation event. The frequency fluctuations do happen between different frequency band limits. This combination has cumulative effect on the loss of blade life which cannot be determined or estimated properly. This complicates the determination of total loss of blade life and protection of turbine during the event. Therefore the manufacturer is required to specify the cumulative time limit for the operation at different frequency band limits. The turbine manufacturer should be consulted to obtain guidance and information on the impact during a multiple frequency band event and how to determine an appropriate protection strategy. Figure 3 illustrates the most restrictive time limitations at various frequencies for operation of some large steam-driven turbine. Table I shows the practical values recommended from National Grid of China.

TABLE I. TURBINE OPERATIONAL LIMITS BY RANGE OF FREQUENCY BANDS

Frequency Band	Frequency Band and Duration Limits		
	Range of Frequency	Individual event time	Cumulative event time
F1	51.0 – 51.5	< 30	< 30
F2	50.5 – 51.0	< 180	< 180
F3	48.5 – 50.5	Continuous Operation	
F4	48.0 – 48.5	< 300	< 300
F5	47.5 – 48.0	< 60	< 60
F6	47.0 – 47.5	< 20	< 10
F7	46.5 – 47.0	< 5	< 2

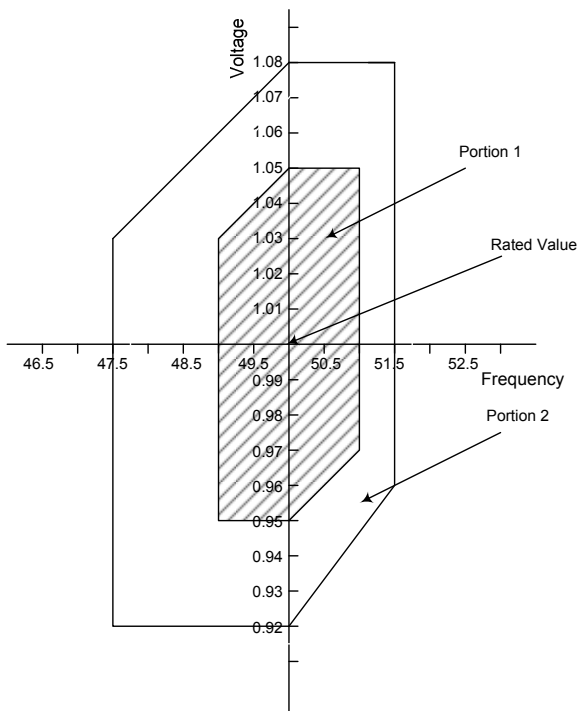

Fig. 4. Voltage and Frequency limits for Turbine

According to IEC standard 60034-1, a machine should be capable of performing its primary function (refer IEC standard 60034-3) continuously within portion 1 as shown in Fig. 4 (shaded Portion). But it need not comply with its performance at rated voltage and frequency and may exhibit some deviations and it may have 10 K temperature rise than at rated voltage and frequency [2]. Extended operation at the perimeter of portion 2 is not recommended.

In practical applications, the turbine is required to operate outside the portion 1 but it should be limited by value, duration and frequency of occurrence. Therefore corrective actions should be taken before the time limitation is reached. For example the rescue can be done by reducing the output which may avoid the reduction in life from temperature effects.

III. OPERATION PRINCIPLE

According to the recommendations from standards IEC 60034-1 and IEEE C37.106, the turbine protection is made by continuously monitoring the frequency of operation and voltage at the system. Each turbine is having its own frequency characteristics and it is defined by the manufacturer. The protection scheme needs the input of permissible time limitation for each frequency band limits. The protection algorithm which are present today has only checking of frequency band limits but it can be extended by using IEC standard 60034-1. This IEC standard propose the voltage band limits monitoring along with frequency band limits and it makes the protection principle different. Figure 5 illustrates the protection algorithm according to IEC standard.

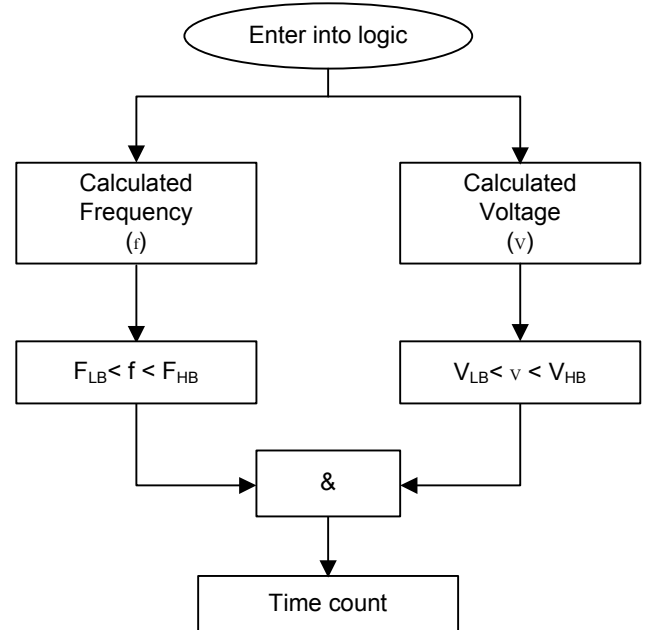

Fig. 5. Turbine Protection Algorithm

As per the above algorithm, the delay time counter for the activation of protection starts once the system frequency and system voltages fall into their band limits. After the delay time counter reaches the time limitation specified for the particular frequency band limit the protection signal is activated. The

protection scheme remains active until the protection of turbine in numerical and mechanical relays has only condition of system frequency falls into the band limit. The additional condition of checking voltage band limit inherently takes care of the voltage to frequency ratio conditions.

The time counter which is mentioned here has to incorporate two timers for the individual event time logging and cumulative event logging. The individual event logging timer should start when the frequency and voltage are within their band limits and should get reset to zero when any of the system parameter either frequency or voltage comes out of their band limits. Regarding the cumulative event logging timer, it should start as same as individual event logging timer but when the system parameters comes out of band limits the timer should retain the logged time and continue when once again the system parameters have fallen inside band limits. Figure 6 shows the cumulative event logging timer with respect to existing algorithm and IEC proposed algorithm.

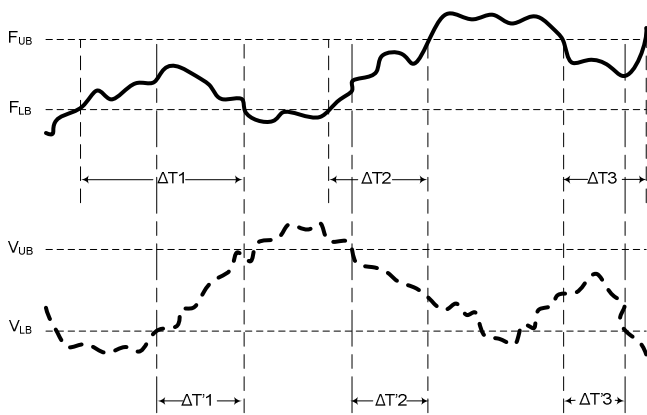

Fig. 6. Cumulative event logging timer principle

Cumulative event timer for

$$\text{Existing Algorithm} = \Delta T_1 + \Delta T_2 + \Delta T_3 + \dots \quad (1)$$

$$\text{IEC Proposed Algorithm} = \Delta T'_1 + \Delta T'_2 + \Delta T'_3 + \dots \quad (2)$$

The IEC proposed protection algorithm [2] do not consider the time when the frequency within the band limit and the voltage outside the band limit for the protection execution. Hence the algorithm will check the time limit with logged time as per Eq. (2).

IV. CONCLUSION

The prime mover of the generator is designed to operate in a narrow frequency ranges and it is typically $\pm 5\%$ which provides a backup protection for the generator protection. As the turbine operates at higher or lower speeds than rated speed the turbine operating frequencies do intersects with natural frequencies of the turbine blade. This creates generator vibrations in the blades and stress on the blades also accumulated resulting in severe damage of turbine. Hence the protection scheme which is presented in this paper do provide diagnostic information and alarms to the customer, based on the accumulated off-nominal frequency operation time of a turbine over several frequency bands and can then be used to schedule maintenance or other actions as desired by the customer.

REFERENCES

- [1] J. Berdy & P. G. Brown, "Protection of Steam Turbine -Generators during Abnormal Frequency Conditions", Georgia Tech Protective Relaying Conference, 1974.
- [2] IEC Rotating Electrical Machines- part 1 Ratings and Performance, IEC Standard 60034 -1, Edition 12.0, 2010-02.
- [3] IEEE Guide for Abnormal Frequency Protection for Power Generating Plants, IEEE Standard C37.106-2003.