

Transverter

Power

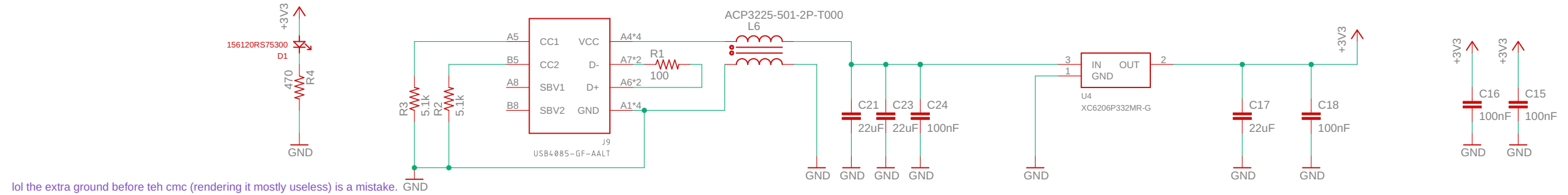

Mixer and Filters

LO Amplifier

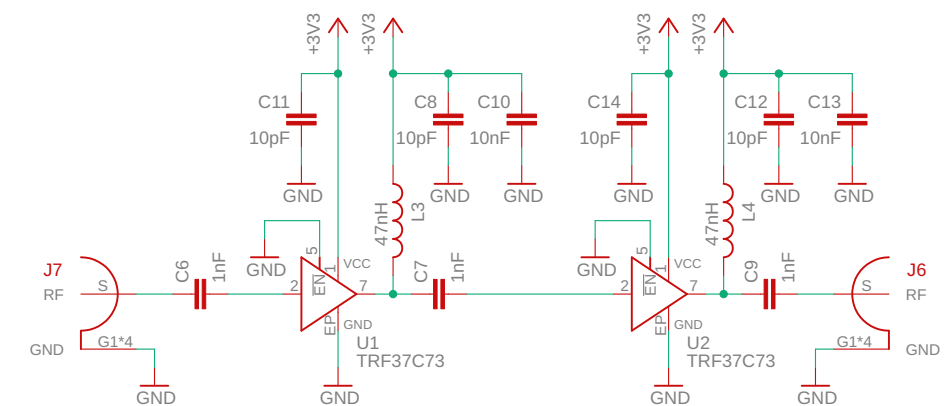
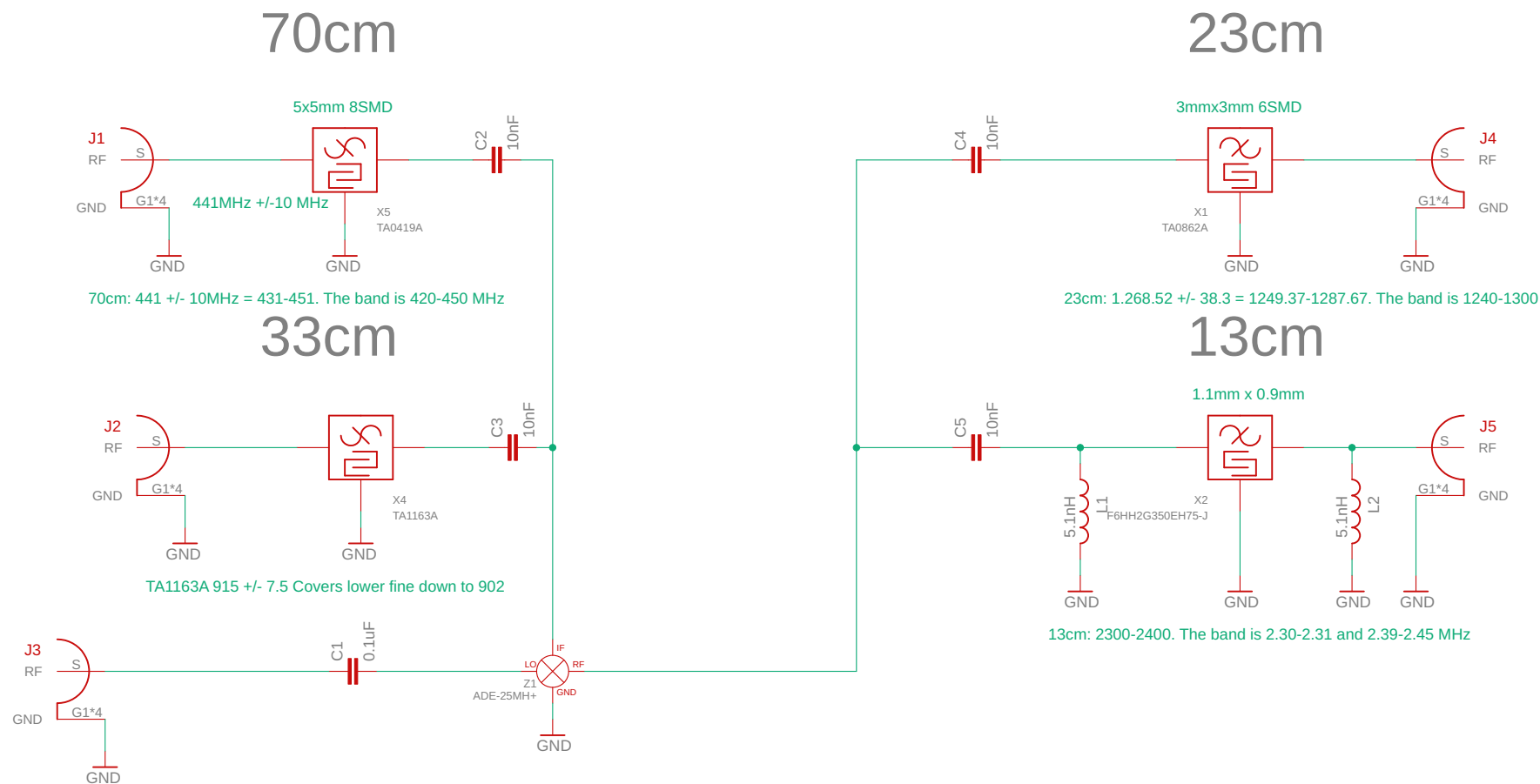

PCB

Use standard 1.6mm JLCPCB Stackup.
Per their calculator, 50Ohm GCPWG lines with 7 mil spacing should be 30.7mm