

General Purpose LNA

LNA

BGU8051: 0.3-1.5 GHz, 0.4dB NF, 14-24dB Gain
BGU8052: 1.5-2.5 GHz, 0.5dB NF, 16-20dB Gain
BGU8053: 2.0-3.8 GHz, 0.6dB NF, 14-20dB Gain

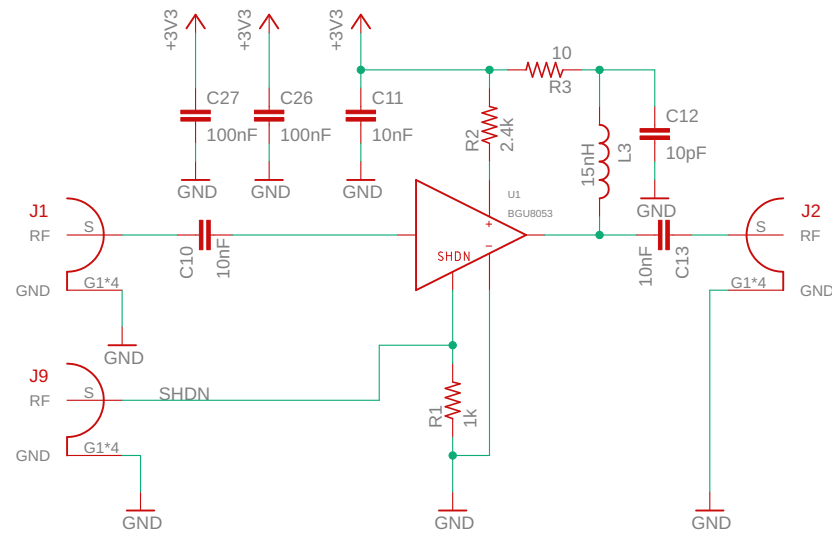

Filters

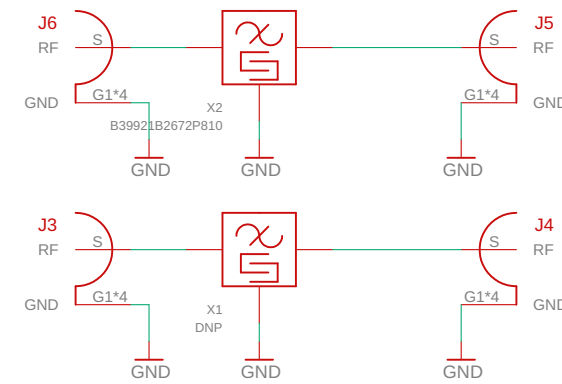

Power

38 mil 50r trace 1.6mil substrate. 6mil gap gcpw

The JLCPCB two layer impedance calculator does not pass a sanity test. Comparing to another GCPWG calculator, the JLCPCB calculator must be assuming a DK of 6.5 which is not correct. I am using a normal GCPWG calculator instead.
<https://chemandy.com/calculators/coplanar-waveguide-with-ground-calculator.htm>

