

IEEE P802.3cg 10Mb/s Single Pair Ethernet: A guide

George Zimmerman (Chair)/CME Consulting

Peter Jones (Ad Hoc Chair)/Cisco Systems

Jon Lewis (Recording Secretary)/Dell EMC

Piergiorgio Beruto/CanovaTech

Steffen Graber/Pepperl+Fuchs

Heath Stewart/Analog Devices

Long Beach, CA, USA January 16th 2019

Agenda

- Why 802.3cg
- What's in 802.3cg
- Multidrop and PLCA
- Concerns about PLCA
- Wrap-up and Q&A

Peter Jones

Jon Lewis

George Zimmerman

George Zimmerman

George, Heath, Jon,

Peter, Piergiorgio, Steffen

What is going on with rates?

- 802.3cg – 10 Mb/s Single Pair(10SPE)
 - Point-to-point 1km full duplex PHY
 - Point-to-point 15m PHY
 - Optional full duplex (mandatory half duplex)
 - Option for half-duplex multidrop - return to CSMA/CD shared-medium networking
 - Supports up to 25m single pair
 - Optional RS (PLCA) to improve performance under load.
 - Repeaters are not specified
- 802.3ch – Multigig Single pair
 - Point-to-point, automotive-reach (15m)

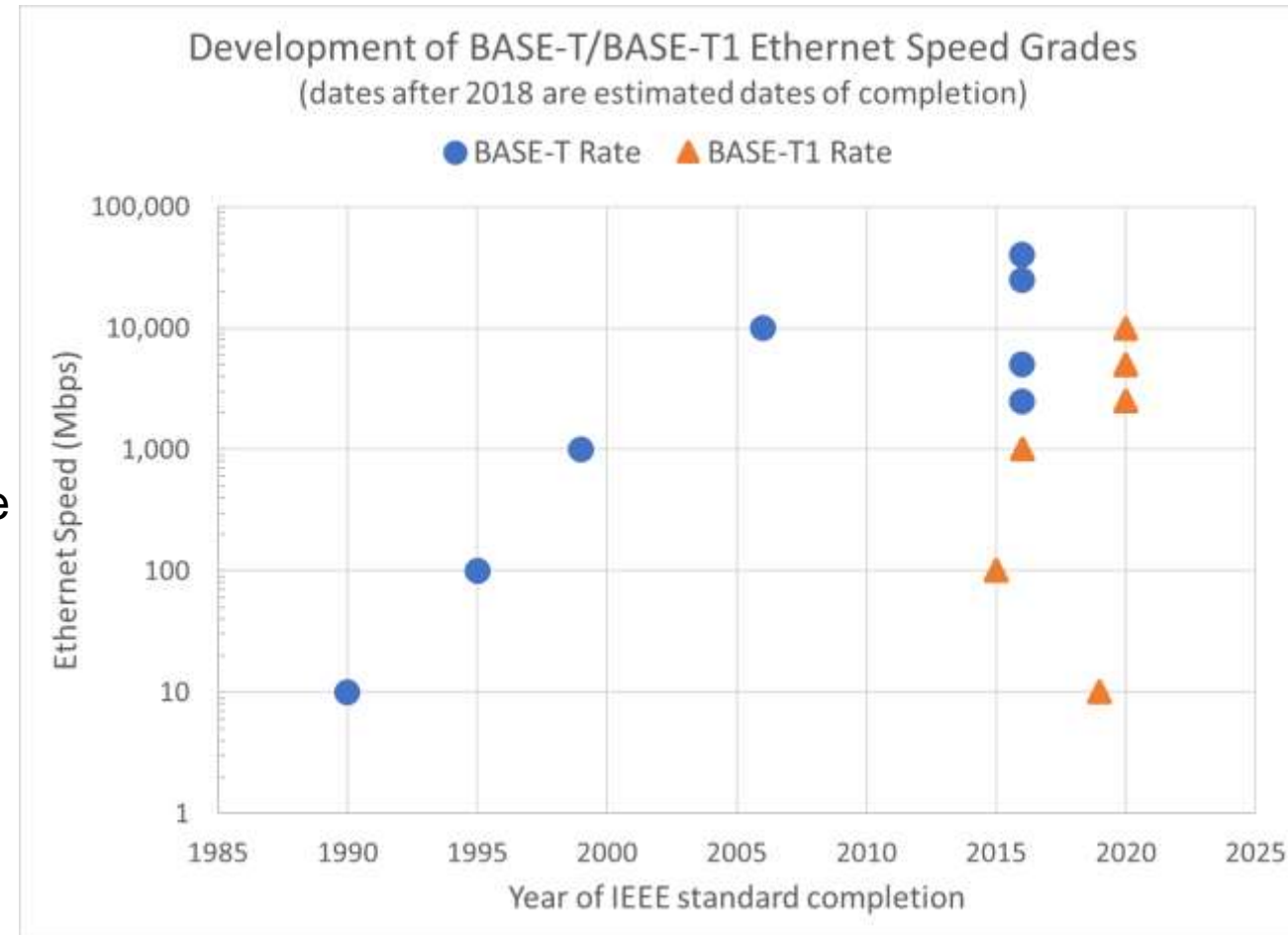

WHY 802.3CG

Peter Jones

Industrial Networking Ethernet Gap

Ethernet Gap in Industrial Networking

- Desire to converge on **one** network type
- Ethernet adoption is happening where technically possible
- Non-Ethernet *fieldbuses* still required to complete communications to the edge
 - Cable lengths > 1km
 - 1200 baud to hundreds of kb/sec
 - Challenges: Combined reach & rate, special environments, cost of operation

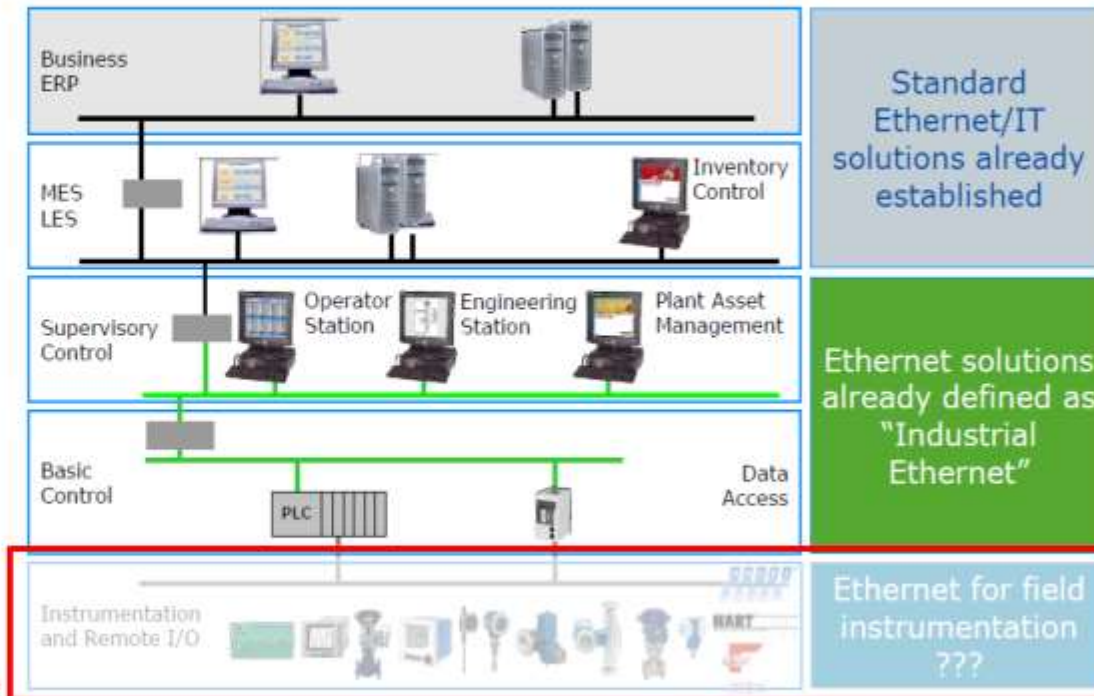

Ethernet Gap at the 'Edge'

Credit: Dr. Raimund Sommer, Endress + Hauser, ODVA Industry Conference, Oct. 2014.

12

Target – Fieldbus Upgrades

Why Single Twisted Pair?

- Enables cable reuse
 - Installed base of Single Twisted Pair, usually shielded
 - Certain cables are certified
 - Lengthy fieldbus cables are expensive to install (often in filled conduit)
 - End nodes are easier to replace
 - Similar value proposition to 2.5G/5GBASE-T Task Force
- Enables constrained form factor applications (sensors etc.)
 - Reduced size and cost

High Cable Reuse Value

Fieldbus	Cable Type	Cable Power
FOUNDATION H1	FF-844 specified	Yes
HART	Various	Yes
PROFIBUS PA	IEC 61158 Type A	Yes
4-20mA	SP-50 instrumentation cable	Yes
CANopen	EIA-485	Yes
Modbus RTU	EIA-485	No
CC-Link	CC-Link, Ver.1.10 specified Shielded, 3- & 5-core	No
DeviceNet	ODVA DeviceNet specified (5-core, various classes)	Yes
ControlNet	RG-6/U Coaxial	No
INTERBUS	3 / 6 no. twisted pairs, various	Yes
PROFIBUS DP	IEC 61158 Type A (22AWG?)	No

21

Target – Fieldbus Upgrades

Why 10Mb/s and Extended Reach?

- ❑ A new solution is required to cover a range of reach and rate with a single design
- ❑ 10Mb/s (a standard MAC) and 1200m address most fieldbus applications
- ❑ Study group will consider, but not expected to cover all extremes/outliers

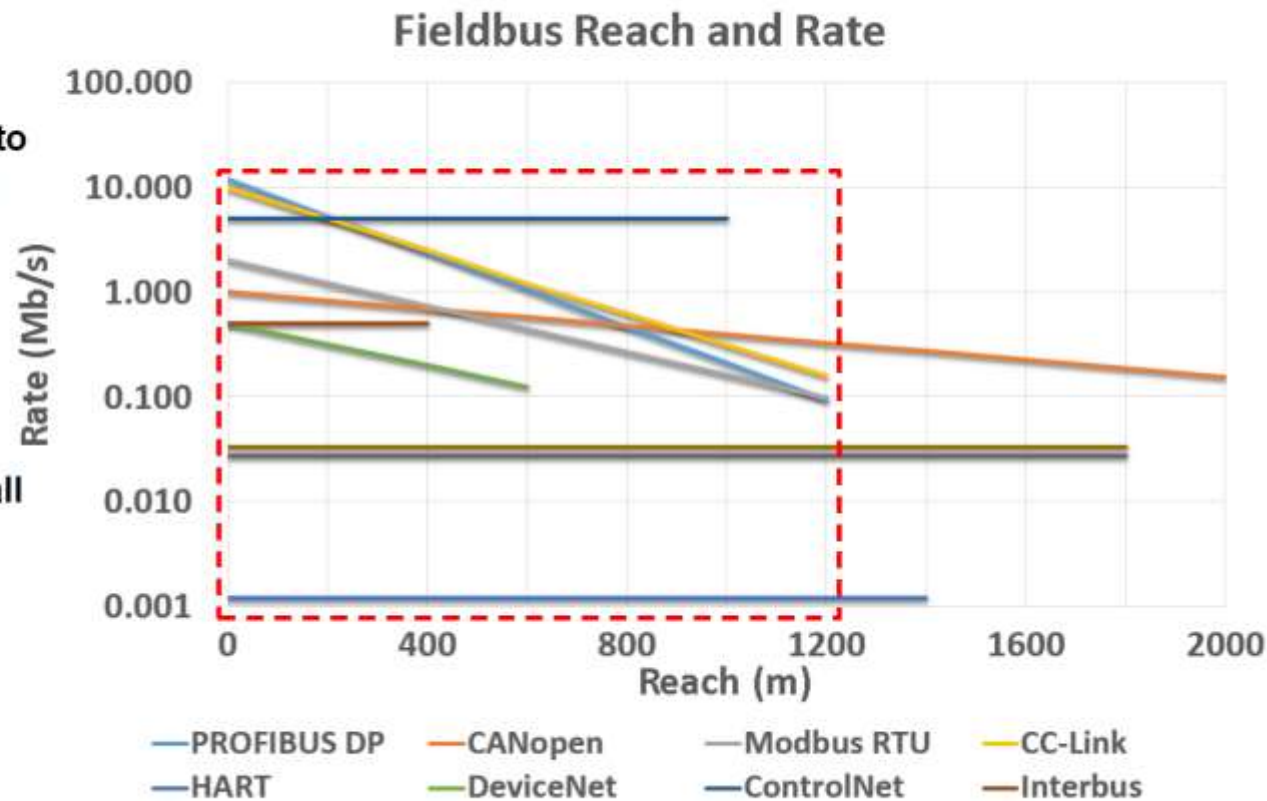

20

Automotive Networking Ethernet Gap

Future look of an all Ethernet IVN

- Everything connected directly to the switch
 - Multiple leaves connected to the same switch port in multi-drop configuration
 - Leaf nodes can be managed via IP protocol directly (service-oriented architecture)
 - You gain all the benefits of Ethernet

- No more gateways: Ethernet supported natively by the leaves
- Integrated PHYs (similar to CAN) and/or NICs

Automotive Networks 2018 Slide 27 The Art of Silicon Sculpting

Source: Canovatech

Example use cases

- Short:
 - In-cabinet, chassis
 - Vehicles
 - Multipoint topologies
- Medium:
 - Industrial pods (5-40m)
 - Building control networks (50-100m)
 - Process control “spurs” (200m)
- Long:
 - Process control trunks (1km)
 - Building automation trunks (500m)
- Application drives cabling (e.g., wire gauge)

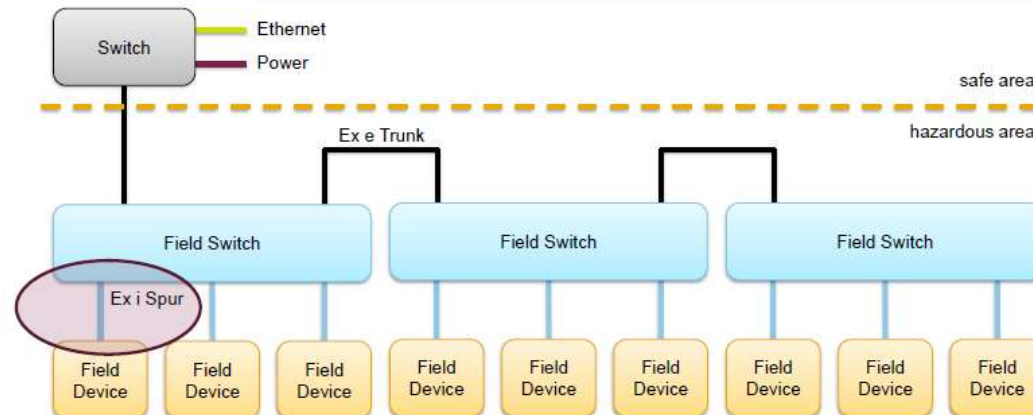
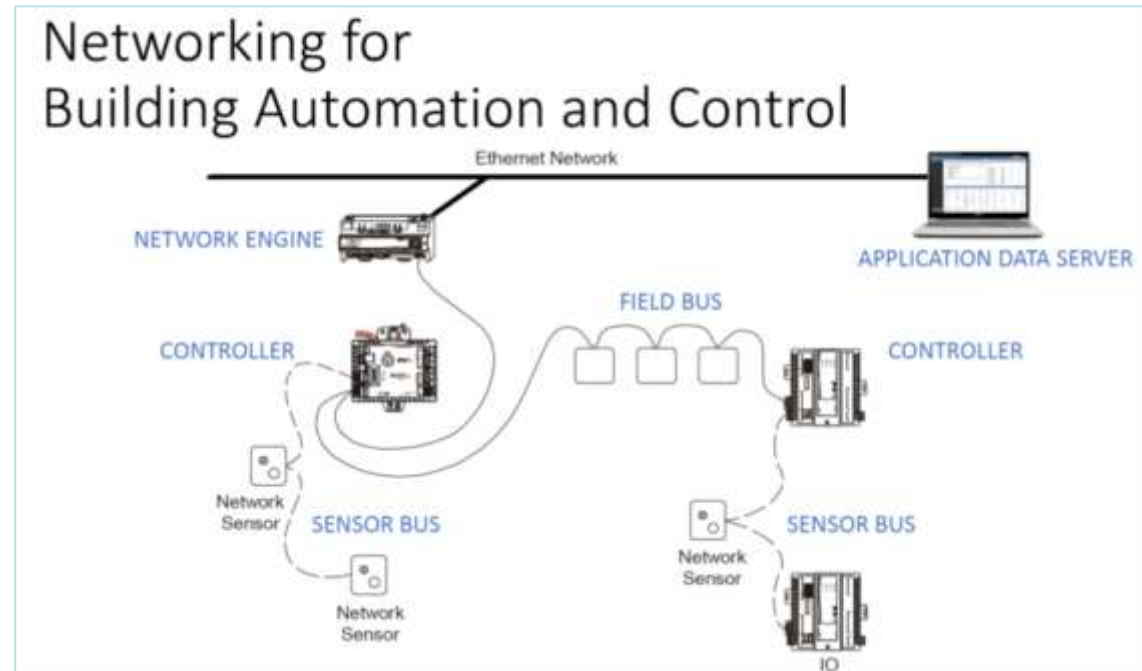

But wait, there's more...

- 10 Mb/s Backplane Ethernet (10BPE) CFI added intra-system use cases (e.g. servers, switches)
- Every time I turn around, someone has a new use....
 - Elevators
 - Fire alarm control (SLC)
 - HVAC control and monitor
 - *<Next Application>*

ETHERNET
Key enabling technology

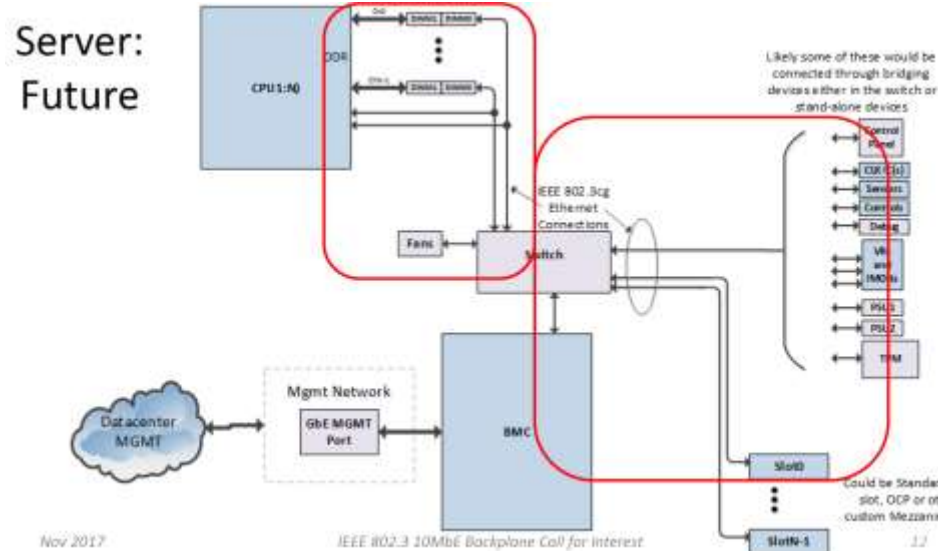

Nov 2017

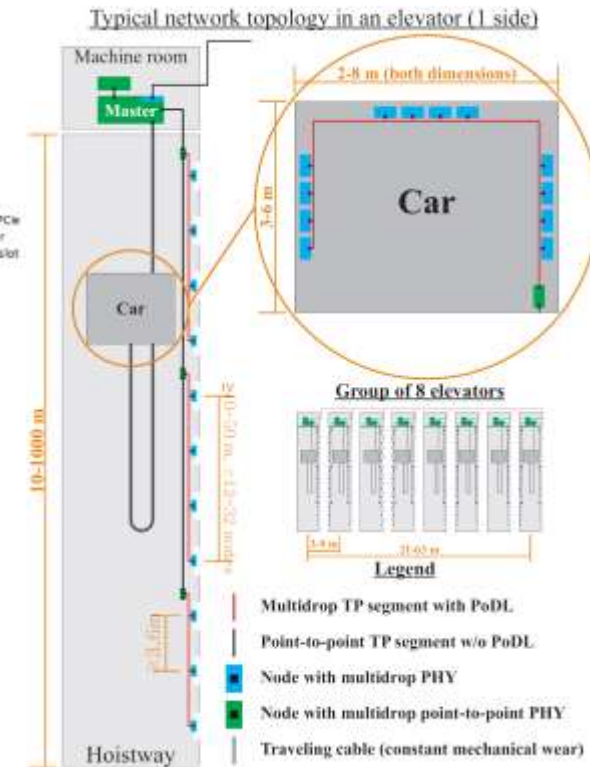
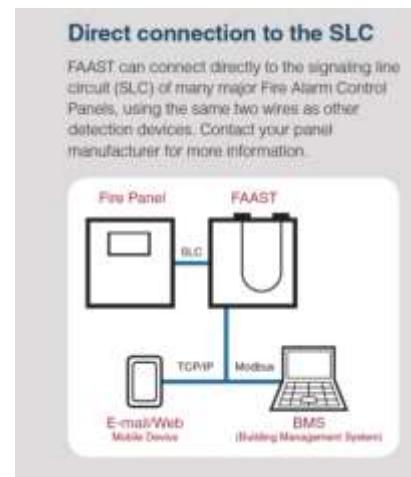

10SPE for Elevators

IEEE 802.3cg 10 Mb/s Single Pair Ethernet (10SPE)

- IEEE 802.3cg single pair Ethernet could be a driver to transform elevators and escalators into Ethernet World
 - 10SPE gives over two magnitudes better bandwidth than legacy systems
 - Multidrop included
 - Power over data line
 - Strong standardization support
- It can be estimate that half of the 20 million nodes per year market could be Ethernet-based in ten years' time



Source: Kone

Example: Control Plane in Servers and Switches

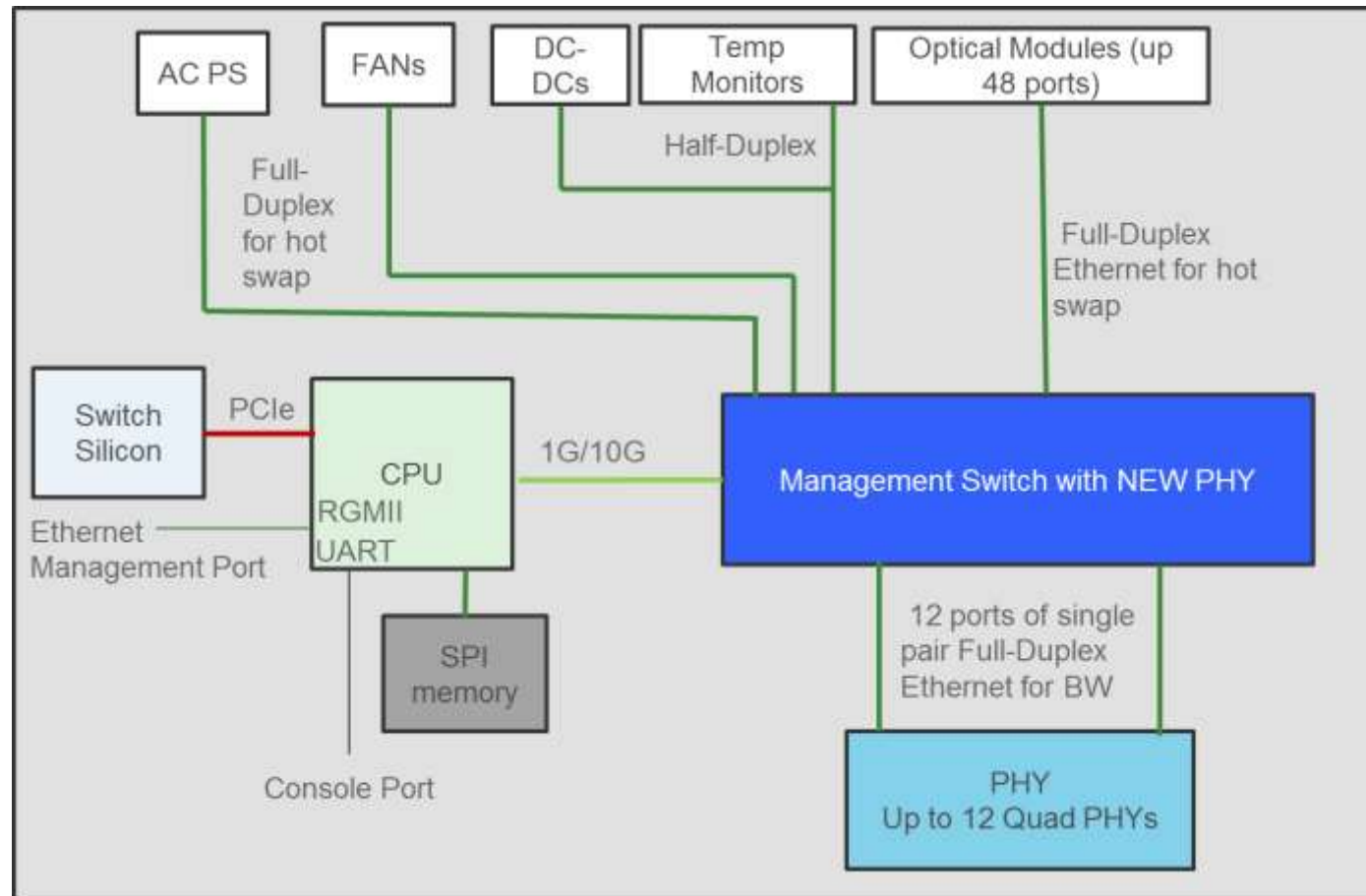

10BASE-T1S for control plane in Ethernet switches

[10Mb/s Backplane Ethernet CFI](#)

WHAT'S IN 802.3CG?

Jon Lewis

BASE-T1 (short reach) Family

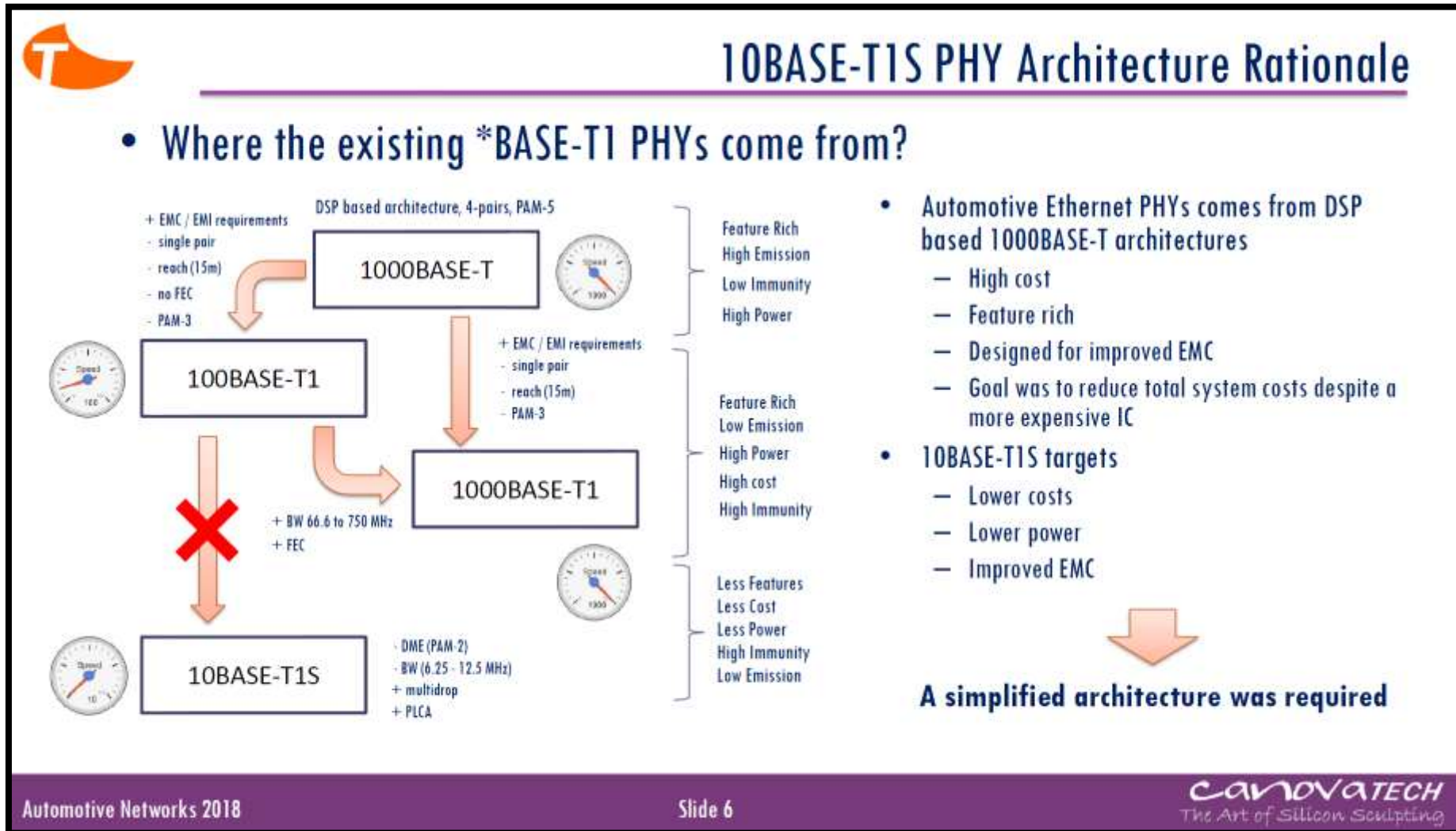

Source: Canovatech

802.3cg key characteristics

2 single balanced pair PHYs

- **10BASE-T1L**: Long reach (1km, 18AWG)
- **10BASE-T1S**: Short reach (15-25m, 24-26AWG)
- Automotive and industrial conditions
- Energy efficiency
- Point to point power (PoDL)
- Half duplex multidrop (T1S)

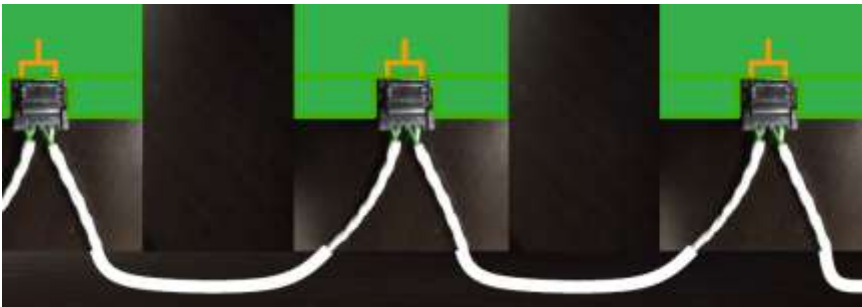

This is Not an Office Environment

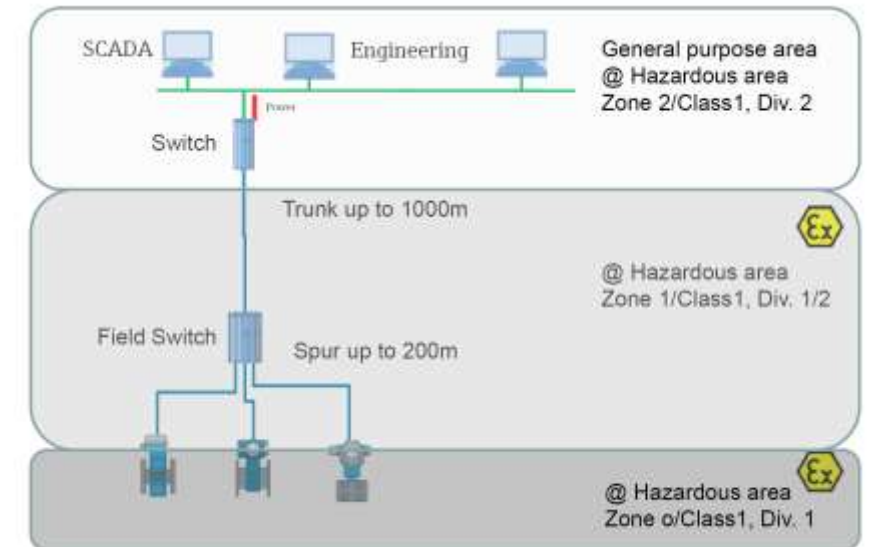

Two PHYs

- 10BASE-T1L: Clause 146, 1km reach
 - Full-duplex point-to-point
 - Optional increased transmit level (e.g., increased noise tolerance)
 - Optional Energy Efficient Ethernet (low power idle)
- 10BASE-T1S: Clause 147, 15m reach (25m for multidrop)
 - Half-duplex point-to-point – base level for interoperability
 - Optional full-duplex point-to-point
 - Optional half-duplex shared-medium/multidrop using CSMA/CD
 - Optional PLCA RS improves performance under load
- Optional Clause 98 Auto-Negotiation

10BASE-T1L Basics

- Simple, echo cancelled, 7.5 MBd full-duplex PHY
 - No FEC, PAM-3 transmission
- 1Vpp, 4B3T encoded signal
 - PCS coding minimizes disparity, keeping signal within voltage bounds (important for industrial applications)
 - Optional 2.4Vpp transmit amplitude Auto-Negotiated
- 1000m reach (18AWG cable)
- “quiet/refresh” EEE (like other BASE-T/BASE-T1 PHYs)
- Example implementations have been demonstrated

10BASE-T1L Example

Evaluation Board Block Diagram

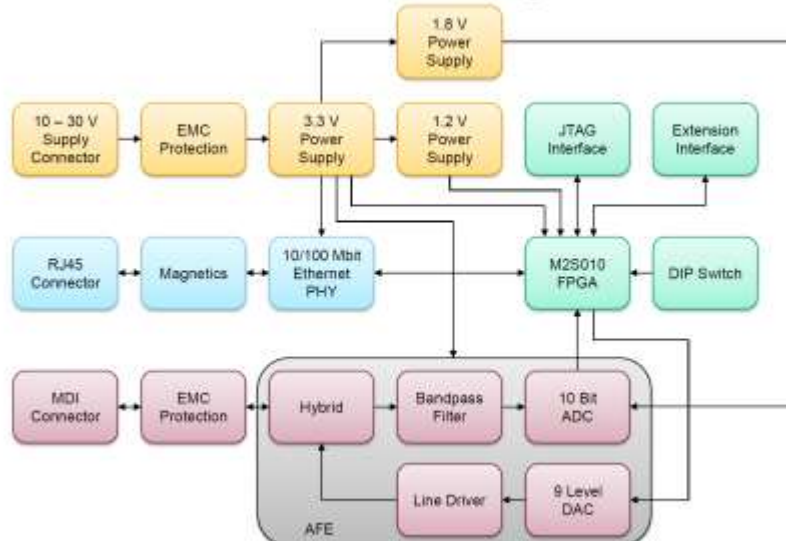

Evaluation Board Assembly

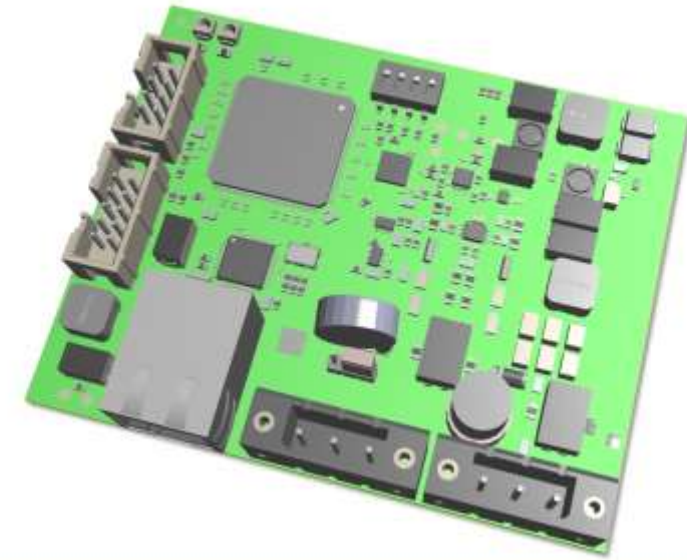

AWGN/Impulsive Noise Measurement Setup

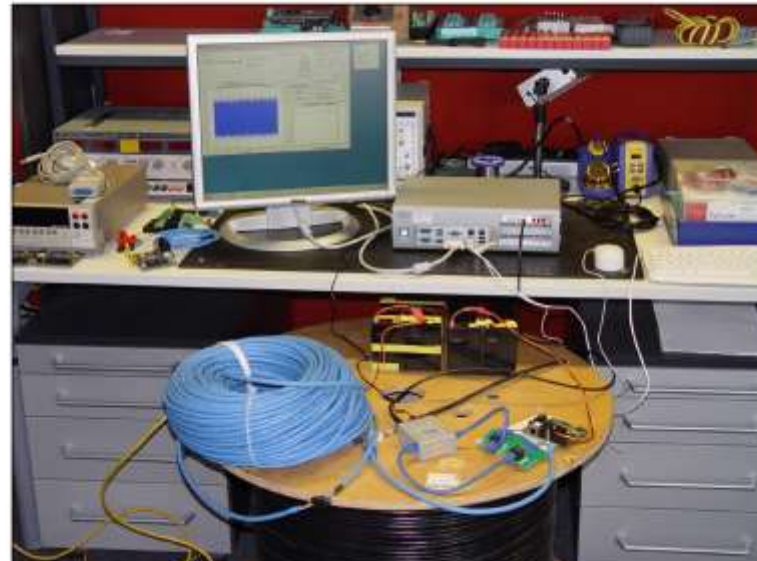

10BASE-T1S basics

- Half-duplex or full-duplex point-to-point (15m)
 - Compatible with PoDL (Clause 104) powering
- Half-duplex multidrop (8 nodes, 25m)
 - Multidrop power not defined in 802.3cg
- 12.5 MBd, 1Vpp, 4B/5B encoded DME signal
 - DME coding enables low cost and multidrop
 - No FEC
- Idle-less DME efficiency means EEE not required
- Example implementations have been demonstrated
 - See, e.g., http://www.ieee802.org/3/cg/public/adhoc/Widger_3cg_01_0918.pdf

BASE-T1 Auto-Negotiation

- As in BASE-T, Auto-Negotiation is key to broad adoption
- Enables multi-speed and multi-mode ports (like 10/100/1000BASE-T)
 - Negotiate link parameters (e.g., 10/100/1000, T1S vs. T1L, loop-timing, EEE)
 - Capabilities exchanged, use “highest common denominator”
 - Capabilities advertised may be restricted by “management”
- BASE-T1 Auto-Negotiation defined in (existing) Clause 98
 - Not compatible with Clause 28 used for BASE-T
 - Uses similar structure from Clause 28 (e.g., base pages/next pages)
 - 60ns clock-to-clock for existing PHYs and T1S
 - T1L adds slower signaling rate (1600ns clock-to-clock) due to link segment bandwidth

AUTO-NEGOTIATION ONLY DEFINED FOR POINT-TO-POINT

Auto-Negotiation signaling rate detection

- Detection of Auto-Negotiation signaling speed added to Clause 98
- Detects partner's DME rate
- Enables Auto-Negotiation between 10BASE-T1L and other BASE-T1 PHYs

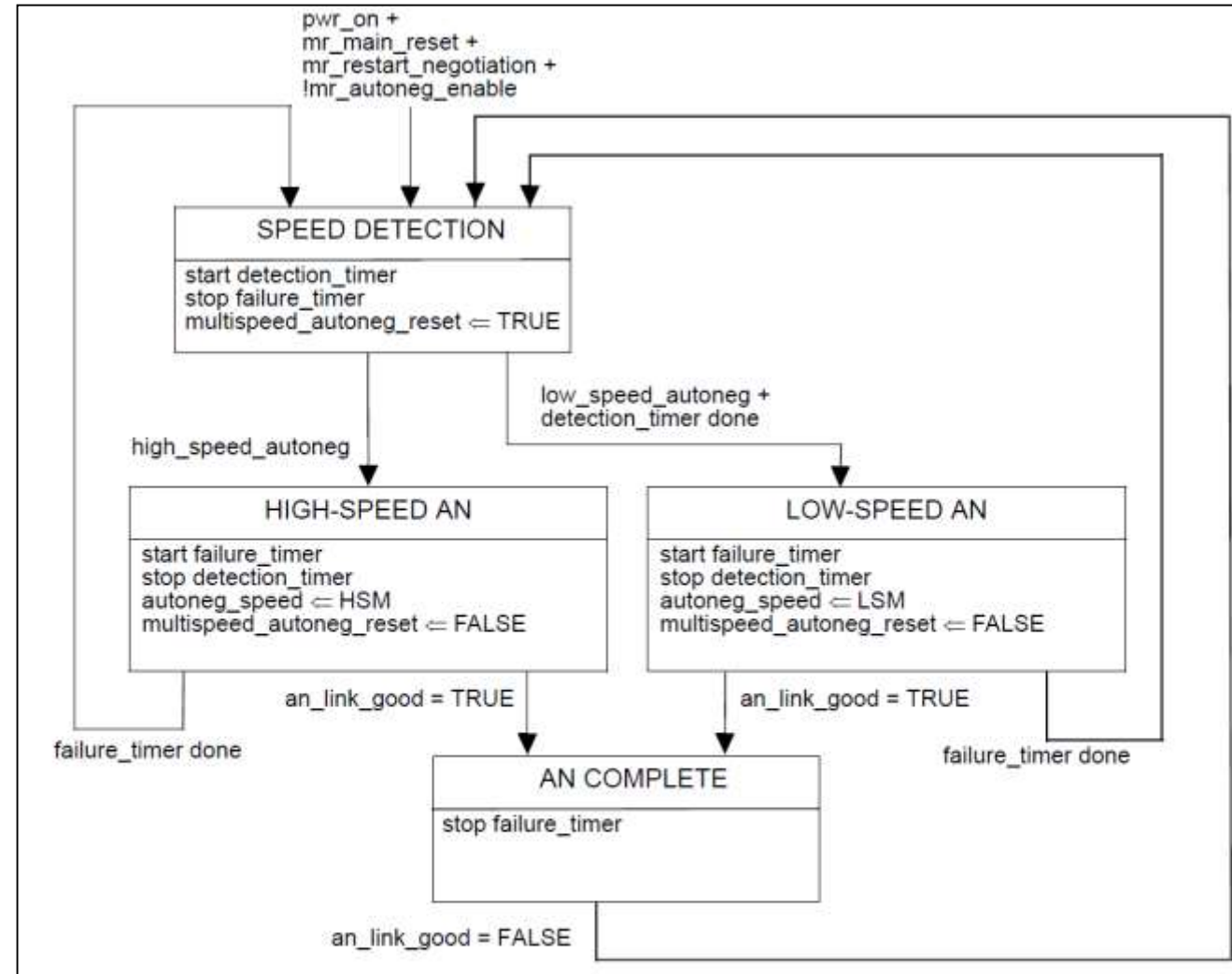

Figure 98-11

PoDL Power – Clause 104 extension

- Interoperable extension of PoDL (constant-power system)
 - Extends loop resistance beyond 6.5 ohms
 - Optimize delivered power using ‘cable resistance measurement’

Class	10	11	12	13	14	15
Ppd (Watts at device)	1.43	2.16	2.35	8.89	13.53	14.24
Vpse (Volts at source)	36	36	36	60	60	60
Loop resistance (ohms)	59	39	36	59	39	36
Length (m)	1000	1000	300	1000	1000	300
Gauge at length	18 AWG	14 AWG	24 AWG	18 AWG	14 AWG	24 AWG

MULTIDROP AND PLCA RECONCILIATION SUBLAYER

George Zimmerman

Multidrop – the ‘mixing segment’

- Linear topology w/stubs
 - Examples in http://www.ieee802.org/3/cg/public/Sept2017/kaindl_matheus_3cg_01c_09_2017.pdf
 - Data in http://www.ieee802.org/3/cg/public/Jan2018/Caliskan_3cg_01a_0118.pdf
- Capacitance limits node count http://www.ieee802.org/3/cg/public/May2018/beruto_3cg_02_0518.pdf
- Gauge limits reach
- Repeaters not specified

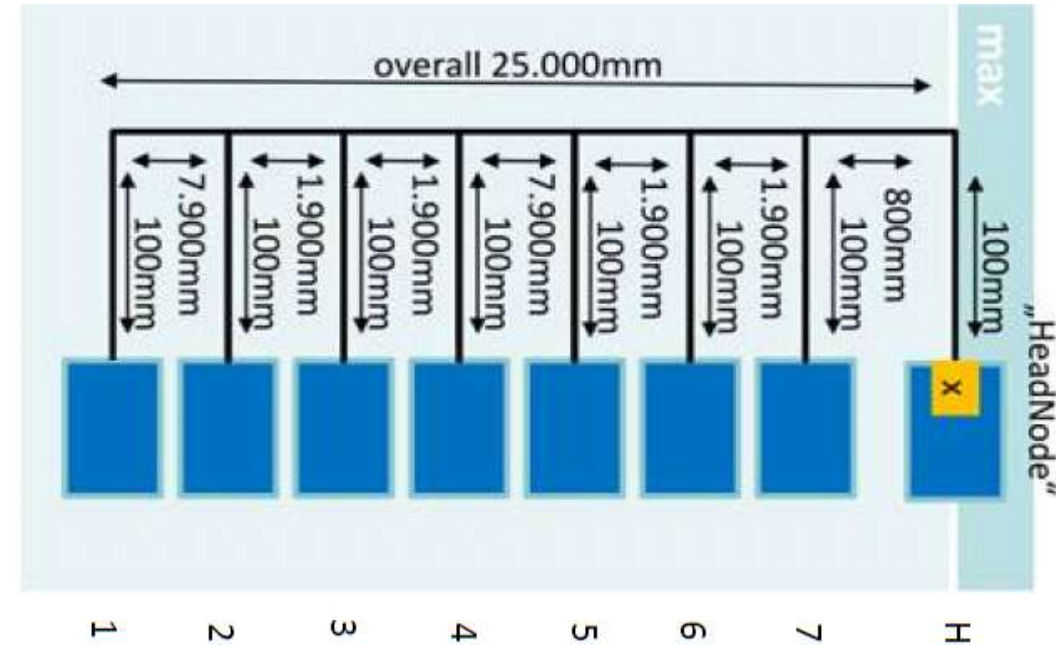

RX Eye Amplitude vs. Node Differential Capacitor and Node Number

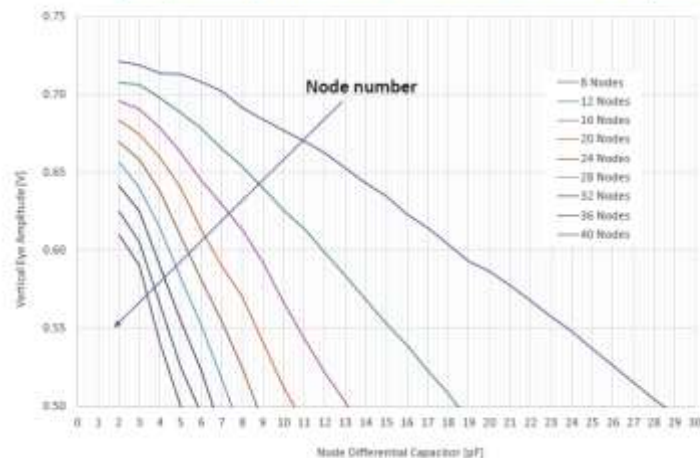

- From such data the maximum capacitance for each node C_{node} and the total capacitance across all nodes C_{tot} the maximum can be extrapolated (sum of all C_{node})
- 500mV RX eye target opening considered

PLCA RS: notable properties

- Provides strict packet fairness
- Requires the half-duplex Clause 4 MAC using CSMA/CD
- Improves utilization and bounds access latency
 - Extends current MII definitions using reserved code points, ignored by existing PHYs
 - Unchanged Clause 4 MAC performs medium allocation and contention resolution
- Basics:
 - A single coordinating station regularly transmits a marker (the BEACON)
 - After each transmitted BEACON, each station is granted a transmit opportunity (TO)
 - Each station (including the coordinating station):
 - Monitors TOs
 - If it has data to send, a station starts transmission only during its TO

Bandwidth under Load*

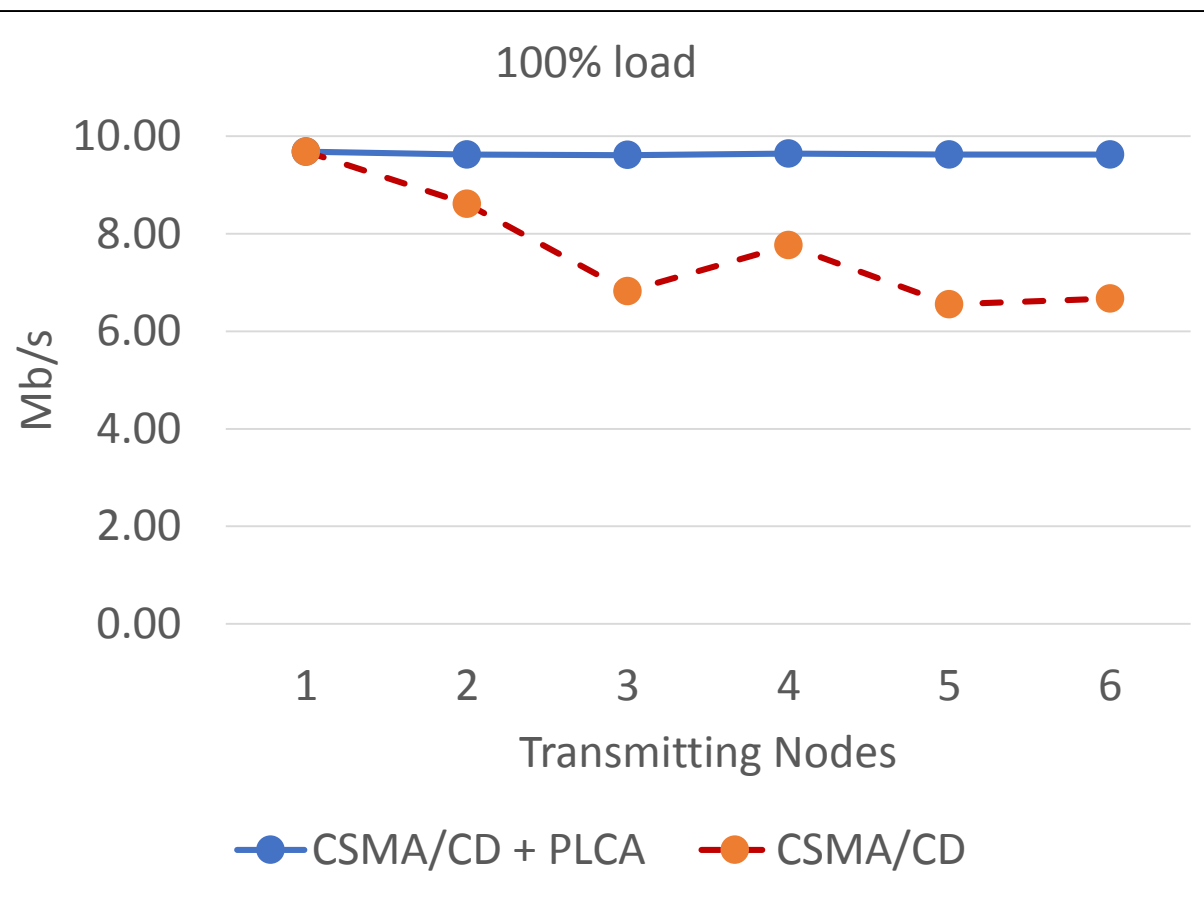
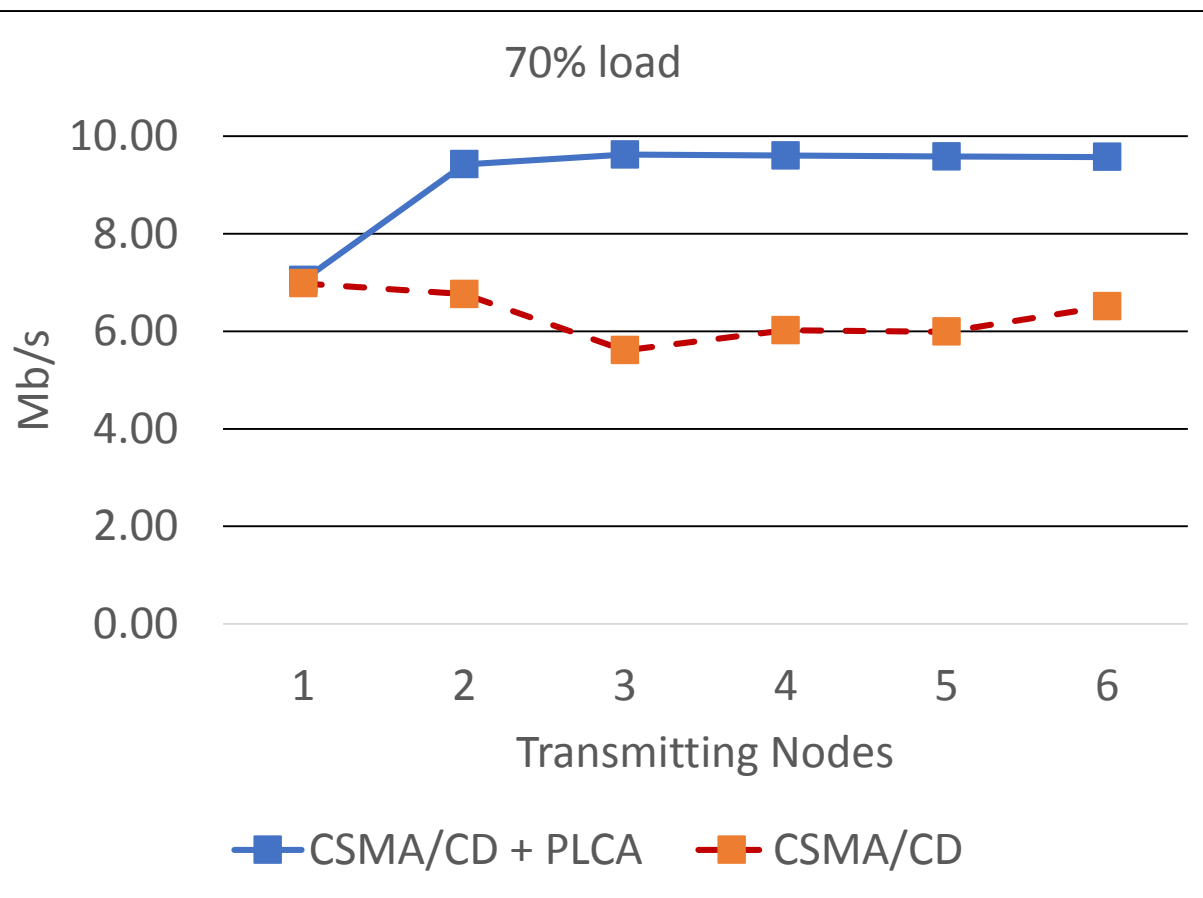

* Simulation example – bandwidth varies

Access Latency under Load*

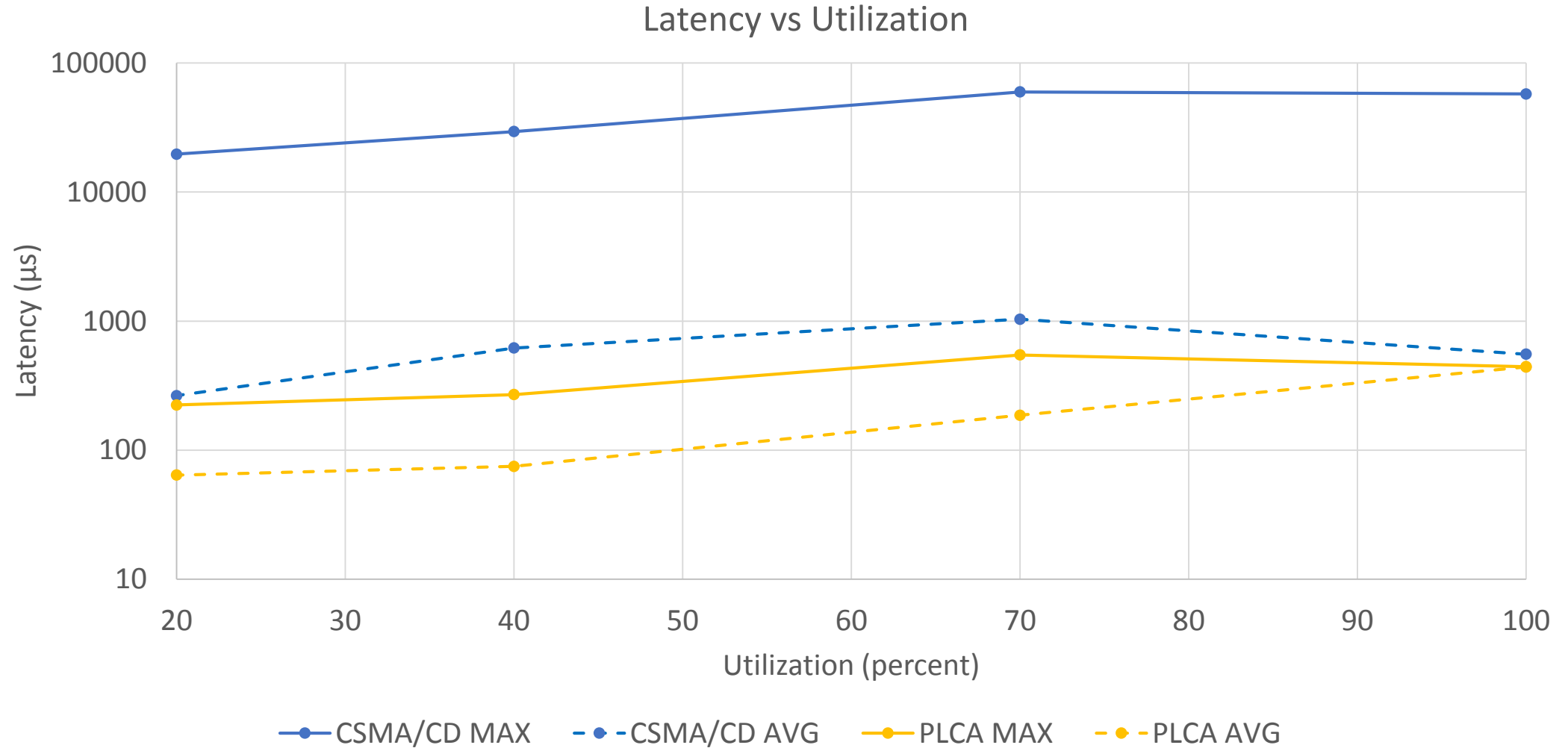

* Simulation example – bandwidth varies

Project Scope

- Approved PAR

2.1 Title: Standard for Ethernet

Amendment: **Physical Layer Specifications** and Management Parameters for 10 Mb/s Operation and Associated Power Delivery over a Single Balanced Pair of Conductors

5.2.b. Scope of the project: Specify additions to and appropriate modifications of IEEE Std 802.3 to add **10 Mb/s Physical Layer (PHY) specifications** and management parameters for operation, and associated optional provision of power, using a single balanced pair of conductors.

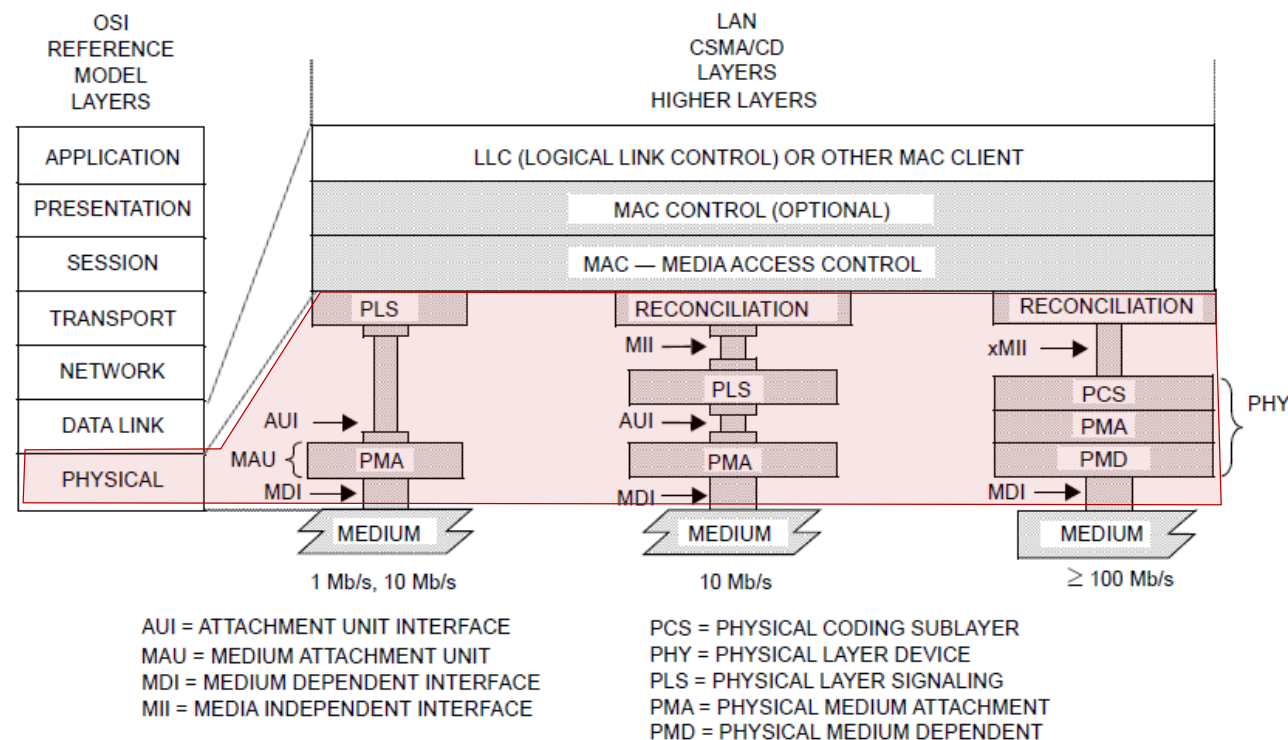

IEEE Std 802.3-2018, Figure 1-1

Existing MCU using MII and PLCA

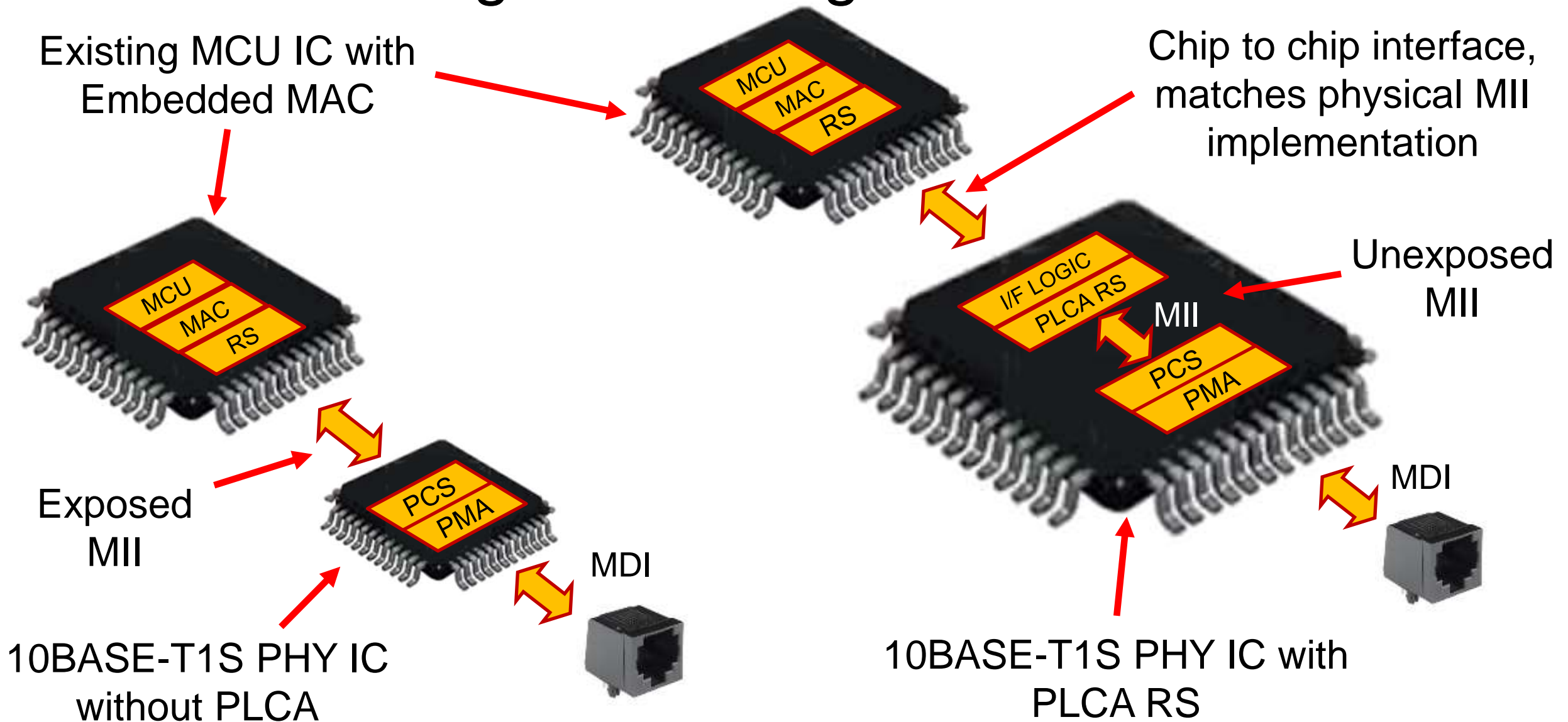

CONCERNS ABOUT PLCA

Concerns Expressed (two commenters)

- “PLCA is a MAC – this is a Physical Layer project”
- “modifying MII breaks compatibility”
- “management is optional, it doesn’t work without management configuration”

Is PLCA a new MAC?

Claim: PLCA is a new MAC

Response:

- PLCA does **NOT interface at the MAC Service Access Point**
- PLCA does **NOT perform MAC functions**, only Physical Layer and Reconciliation Sublayer functions
- IEEE Std. 802.3 Clause 4.1.1 Media Access Control functions:
 - Data encapsulation (transmit and receive) – **PLCA doesn't do any of these**
 - Framing (frame boundary delimitation, frame synchronization)
 - Addressing (handling of source and destination addresses)
 - Error detection (detection of physical medium transmission errors)
 - Media Access Management - Medium allocation (collision avoidance)
 - PLCA performs normal PHY functions of Collision Detect and Carrier Sense and sends these to the Clause 4 MAC
 - **PLCA does these Physical Layer functions**
 - PLCA delays data to align for and enable collision detect
 - **PLCA does this (normal RS function)**
 - **Clause 4 MAC** holds back frames based on CRS and COL
 - **PLCA does not do this**
 - Contention resolution (collision handling)
 - **PLCA does not do this**

PLCA does not perform MAC functionality

http://www.ieee802.org/3/cg/public/adhoc/zimmerman_3cgah_01a_100318.pdf

Specified PLCA functions are currently defined as Physical Layer functions in 802.3

- PLCA functions of providing carrier sense and collision detect, and using a variable delay to align data, **are already specified in 802.3-2018 Ethernet as Physical Layer functions**
- Clause 4 is clear – Carrier Sense and Collision Detect are provided by the **Physical Layer**
 - 4.1.2.1.1 Transmission without contention (under Normal Operation of CSMA/CD)
 - “In half duplex mode, Transmit Media Access Management attempts to avoid contention with other traffic on the medium by monitoring the carrier sense signal provided by the Physical Layer Signaling (PLS) component and deferring to passing traffic.”
 - 4.2.3.2.4 Collision detection and enforcement
 - “Collisions are detected by monitoring the collisionDetect signal provided by the Physical Layer.”
- XGMII-based implementations (and later xMII) **already use variable delays for alignment between MAC and PHY timing**
 - 46.3.1.4 Start control character alignment
 - “On transmit, it may be necessary for the RS to modify the length of the <inter-frame> in order to align the Start control character (first octet of preamble) on lane 0.”
 - Subsequent RS’s perform alignment similarly (CI 106 & CI 81)

These functions are within the Physical Layer (including RS)!

Detail: MII compatibility

- Claim: PLCA violates CSD requirements about MII (http://www.ieee802.org/3/cg/public/Nov2018/Kim_3cg_01_1118.pdf slides #4-6)
 - “As a PHY amendment to IEEE Std 802.3, the proposed project will use MII ...”
- Response:
 - PLCA has full MII compatibility
 - In PHY direction, PLCA RS adds signaling on top of MII in reserved code space (same as EEE did) - No impact on existing PHY specifications:
 - Existing text in 22.2.24: “For EEE capability, the RS shall use the combination of TX_EN deasserted, TX_ER asserted, and TXD<3:0> equal to 0001 as shown in Table 22–1 as a request to enter, or remain in a low power state. **Other values of TXD<3:0> with this combination of TX_EN and TX_ER shall have no effect upon the PHY**”
 - PHY implementations prior to PLCA introduction ignore the newly added combinations!
 - Backward compatibility is preserved, as happened when EEE was introduced.
 - In MAC direction, PLCA asserts Collision Detect and Carrier Sense – defined in Clause 4 to be provided by the Physical Layer

Detail: CL4 MAC compatibility

- Claim: PLCA is not compatible with existing MAC
(http://www.ieee802.org/3/cg/public/Nov2018/Kim_3cg_01_1118.pdf, slide 5)
- Response:
 - There are no modifications to the MAC (Clause 4) in 802.3cg draft.
 - Normative part of Clause 4 is specified in the form of Pascal code
 - The PLCA RS maps between PLS primitives and the MII (see 148.4.3)
 - PLCA implementations have been successfully tested against existing MAC implementations
(<http://www.ieee802.org/3/cg/public/July2018/PLCA%20overview.pdf>, slides #19-21)

What about Management?

Claim: PLCA is not interoperable because it relies on management configuration which (commenter claims) is optional

(http://www.ieee802.org/3/cg/public/Nov2018/Kim_3cg_01_1118.pdf slides #10-12)

Response:

- Is management optional?
 - MDIO as an electrical interface and register set is optional.
 - A ubiquitous management entity isn't optional – in many cases 'equivalent functionality' needs to be provided if MDIO isn't present, or there are fall-back defaults.
- PLCA requires configuration to give enhanced performance, otherwise performance is normal half-duplex CSMA/CD
 - Interoperable, just not enhanced.

WRAP-UP AND Q&A

802.3cg in a Nutshell

- Industrial, Automotive, Building & Intra-system 10Mb/s Networking
 - Optional power and multidrop
- 2 PHYs, 1 Reconciliation Sublayer, and PoDL extension
 - Long reach, full duplex 10BASE-T1L – Clause 146
 - Clause 98 extension (slower speed Auto-Negotiation for 10BASE-T1L)
 - Short reach, half duplex 10BASE-T1S – Clause 147
 - Options: full duplex point-to-point, half duplex multidrop
 - PLCA RS for enhanced multidrop performance – Clause 148
 - ***Performs only Physical Layer functions already in 802.3***
 - PoDL extension – Clause 104
 - More power classes, greater loop resistance, and cable resistance measurement

PANEL & Q&A

Thank You!